

2 POST PLAIN BEARING ALL STEEL DIE SET  
DIAGONAL POST MODEL # 2PD

2 POST PLAIN BEARING ALL STEEL DIE SET  
CENTER POST MODEL # 2PC

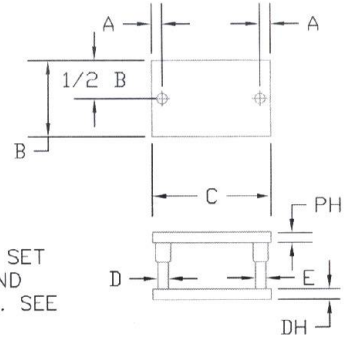

QUALITY TOOL & ENGINEERING  
P. O. BOX 338  
350 BRYANT LANE  
WOODBURY, TN 37190

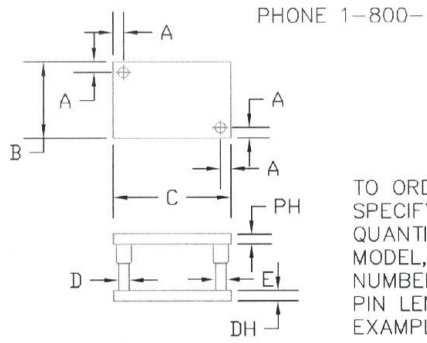

TO ORDER SPECIFY:  
QUANTITY,  
MODEL, DIE SET  
NUMBER, AND  
PIN LENGTH. SEE  
EXAMPLES.

EXAMPLE: (1) 2PD-1416-0708 X 9

EXAMPLE: (1) 2PC-1416-0708 X 9

FRONT TO BACK B	LEFT TO RIGHT C	THICKNESS OF		DIE SET NUMBER	PIN DIA. D	PIN DIA. E	TAB A
		PUNCH HOLDER PH	DIE HOLDER DH				
8	10	1 1/4	1 1/2	0810-0506	1 1/4	1	1 5/8
		1 1/2	1 1/2	0810-0606			
		1 1/2	1 3/4	0810-0607			
10	12	1 3/4	1 3/4	0810-0707	1 1/2	1 1/4	1 3/4
		1 1/4	1 1/2	1012-0506			
		1 1/2	1 1/2	1012-0606			
12	12	1 1/2	1 3/4	1012-0607	1 1/2	1 1/4	1 3/4
		1 3/4	1 3/4	1012-0707			
		1 1/4	1 1/2	1212-0506			
10	14	1 1/2	1 1/2	1212-0606	1 1/2	1 1/4	1 3/4
		1 1/2	1 3/4	1212-0607			
		1 3/4	1 3/4	1212-0707			
12	14	1 1/4	1 1/2	1014-0506	1 1/2	1 1/4	1 3/4
		1 1/2	1 1/2	1014-0606			
		1 1/2	1 3/4	1014-0607			
14	14	1 3/4	1 3/4	1014-0707	1 3/4	1 1/2	1 7/8
		1 1/2	1 1/2	1214-0506			
		1 1/2	1 1/2	1214-0606			
12	16	1 1/2	1 3/4	1214-0607	1 3/4	1 1/2	1 7/8
		1 3/4	1 3/4	1414-0507			
		1 3/4	2	1414-0707			
14	16	1 1/2	1 1/2	1416-0606	2	1 3/4	2
		1 1/2	1 3/4	1416-0607			
		1 3/4	1 3/4	1416-0708			

FRONT TO BACK B	LEFT TO RIGHT C	THICKNESS OF		DIE SET NUMBER	PIN DIA. D	PIN DIA. E	TAB A
		PUNCH HOLDER PH	DIE HOLDER DH				
16	16	1 1/2	1 3/4	1616-0607	2	1 3/4	2
		1 3/4	1 3/4	1616-0707			
		1 3/4	2	1616-0708			
12	18	1 1/2	1 3/4	1218-0607	2	1 3/4	2
		1 3/4	1 3/4	1218-0707			
		1 3/4	2	1218-0708			
14	18	2	2	1218-0808	2	1 3/4	2
		1 1/2	1 3/4	1418-0607			
		1 3/4	1 3/4	1418-0707			
16	18	1 3/4	1 3/4	1418-0707	2	1 3/4	2
		1 3/4	2	1618-0708			
		2	2	1618-0808			
18	18	1 1/2	1 3/4	1818-0607	2	1 3/4	2
		1 3/4	1 3/4	1818-0707			
		1 3/4	2	1818-0708			
14	20	1 1/2	1 3/4	1420-0607	2	1 3/4	2
		1 3/4	1 3/4	1420-0707			
		1 3/4	2	1420-0708			
16	20	1 1/2	1 3/4	1620-0607	2	1 3/4	2
		1 3/4	1 3/4	1620-0707			
		1 3/4	2	1620-0708			
20	20	1 1/2	1 3/4	2020-0607	2	1 3/4	2
		1 3/4	1 3/4	2020-0707			
		1 3/4	2	2020-0708			



CALL AND ASK ABOUT OUR SPECIAL  
ECONOMY LITE DUTY I X I X I DIE SETS  
AND SAVE MONEY

OTHER SIZES, THICKNESS, AND PIN DIAMETERS  
ARE AVAILABLE :

TO ORDER SPECIFY: QUANTITY, MODEL, FRONT TO BACK DIM, LEFT TO RIGHT DIM, PUNCH HOLDER THICKNESS, DIE HOLDER THICKNESS, LARGER PIN DIA, & PIN LENGTH.  
OTHER SERVICES INCLUDE: DIFFERENT PIN LOCATIONS, BALL BEARINGS, TORCH CUT SLUG HOLES, MILLED POCKETS, BOLT HOLES, FINISHED EDGES, DEMOUNTABLE BUSHINGS. AND YOU NAME IT.

QUALITY TOOL & ENGINEERING HAS BEEN MANUFACTURING PRECISION DIE SETS FOR OUR CUSTOMERS SINCE 1971. WE HAVE BEEN CONCENTRATING ON JUST A FEW SELECT CUSTOMERS. WE ARE NOW HOPING TO EXPAND OUR CUSTOMER BASE TO INCLUDE YOUR COMPANY. PLEASE CALL US FOR A QUOTE ON YOUR NEXT DIE SETS.

QUALITY TOOL & ENGINEERING IS ALSO A MODERN MACHINE SHOP WITH BLANCHARD GRINDING CAPABILITIES OF 84" ACROSS CORNERS. WE HAVE SEVEN CNC MACHINING CENTERS WITH CAPABILITIES OF 30" X 60". WE HAVE FOUR WIRE EDM MACHINES WITH CAPACITIES OF 23" X 31" X 9" THICK. WE ALSO HAVE JIG GRINDING AND JIG BORING CAPABILITIES. PLEASE LET US KNOW HOW WE CAN HELP YOU.

PHONE 1-888-535-5434 TOLL FREE

PHONE 1-888-535-5434 TOLL FREE